

# ORDER FORM

CUSTOMER INFO

COMPANY NAME: \_\_\_\_\_  
 CONTACT: \_\_\_\_\_  
 PURCHASE ORDER #: \_\_\_\_\_  
 PHONE #: \_\_\_\_\_  
 FAX #: \_\_\_\_\_  
 EMAIL ADDRESS: \_\_\_\_\_

BILLING ADDRESS: \_\_\_\_\_  
 CITY: \_\_\_\_\_  
 STATE: \_\_\_\_\_  
 ZIP CODE: \_\_\_\_\_

SHIP TO ADDRESS: \_\_\_\_\_  
 CITY: \_\_\_\_\_  
 STATE: \_\_\_\_\_  
 ZIP CODE: \_\_\_\_\_  
 SHIPPING METHOD: \_\_\_\_\_

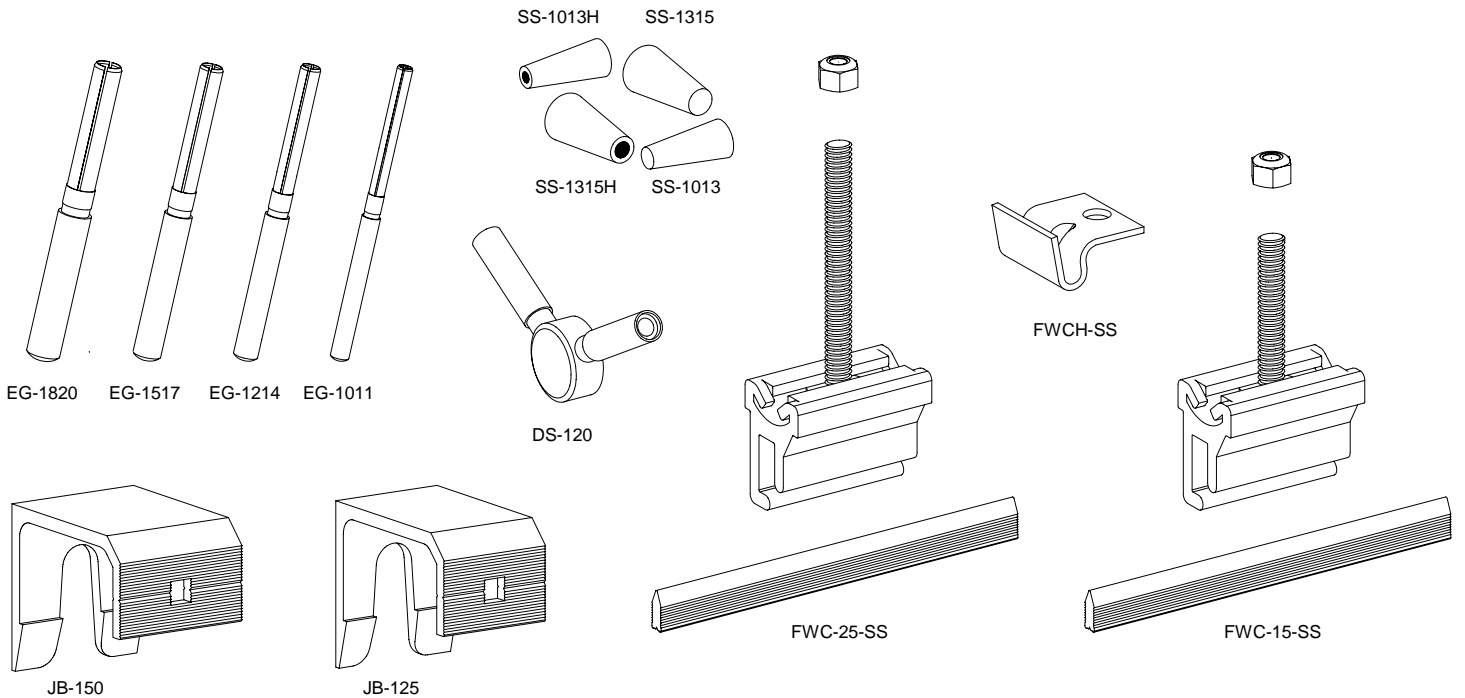

QTY	DESCRIPTION	PART #	PRICE	TOTAL
	FLEXI-WEDGE CLAMP ASSM. 1 1/2 " BOLT	FWC-15-SS		
	FLEXI-WEDGE CLAMP ASSM. 2 1/2 " BOLT	FWC-25-SS		
	FLEXI-WEDGE ATTACHMENT HOOK	FWCH-SS		
	J-BRACKET 1 1/4 " WIDTH	JB-125		
	J-BRACKET 1 1/2 " WIDTH	JB-150		
	BRASS DOUBLE SWIVEL 120 °	DS-120		
	BRASS ELECTRODE GRIP 10MM TO 11MM	EG-1011		
	BRASS ELECTRODE GRIP 12MM TO 14MM	EG-1214		
	BRASS ELECTRODE GRIP 15MM TO 17MM	EG-1517		
	BRASS ELECTRODE GRIP 18MM TO 20MM	EG-1820		
	SILICONE STOPPER 10MM TO 13MM W/ HOLE	SS-1013H		
	SILICONE STOPPER 10MM TO 13MM W/O HOLE	SS-1013		
	SILICONE STOPPER 13MM TO 15MM W/ HOLE	SS-1315H		
	SILICONE STOPPER 13MM TO 15MM W/O HOLE	SS-1315		

SUB TOTAL:	
FREIGHT:	
TOTAL:	

**Sign  
Specialties  
Incorporated**

120 15TH ST NE, WATERTOWN, SD 57201  
 PH #: (605) 886-4545 FAX #: (605) 886-5514